

Product: KLUDI LOGO NEO single lever basin mixer DN 10

Ref.: 372830575

Product description

single lever basin mixer DN 10
 solid lever
 single hole mounted
 flow class Z
 eco-aerator M 24 x I
 ceramic cartridge with hot water safety device
 retractable chain
 rapid installation set
 flexible high pressure supply tubes 3/8 inch
 noise group I
 P- IX 19334/IZ

Finishes:
 chrome

Product picture



Advertisement

- * KLUDI GmbH & Co KG KLUDI LOGO NEO single lever basin mixer DN 10 item no. 372830575
- ** ceramic cartridge with hot water safety device Ø 35 mm, DIN EN 817
- *** chrome plated brass, DIN 50930-6

single lever basin mixer, manufacturer KLUDI GmbH & Co KG KLUDI LOGO NEO single lever basin mixer item no. 372830575, DN 10, chrome plated brass, solid lever, noise level DIN 4109 group I, report no. P- IX 19334/IZ, type: single lever basin mixer DN 10, flow class Z (max. 0,15 l/s), eco aerator M 24 X I Z, ceramic cartridge with hot water safety device Ø 35 mm, retractable chain, flexible high pressure supply tubes G 3/8 with DVGW / KIWA / WRAS / CSTB with metal body length 350 mm, nozzle projection 115 mm, nozzle height 65 mm, lever projection 83 mm, rapid installation set, overall length 126 mm, for pressure type water heater, for continuous line heater, PN 10,

Dimensional drawing

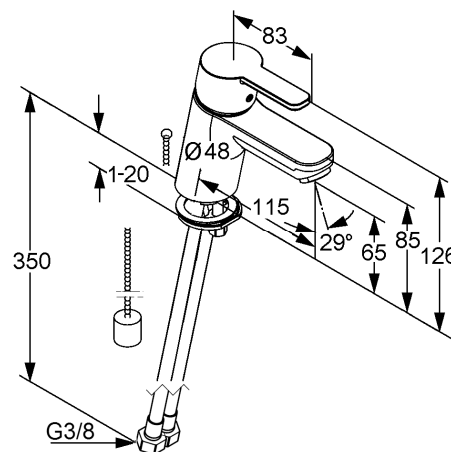

Flow rate diagram

